



Fast Accurate Cost-effective

AQ6150 Series Optical Wavelength Meter

Precision Making

Bulletin AQ6150SR-01EN



Recently, in order to enable the new optical networks for IoT or the next-generation communication “5 G”, WDM (Wavelength Division Multiplexing) technology has been widely used from backbone to access. New optical components and devices for such new technologies need to be tested to measure individual optical wavelengths with a higher accuracy.

Our extensive experience working with customers in the optical Test & Measurement Industry has enabled us to design the world’s most reliable and versatile Optical Wavelength Meters. In fact, they feature specific technical characteristics that make them the most efficient and effective instruments for measuring devices and systems used in the most demanding applications of photonic technology.

Yokogawa’s AQ6150 Series can satisfy the specific test and measurement needs of R&D and manufacturing centers belonging to these demanding industries.

Reliability – The most trusted optical wavelength meters in the world, thanks to their unmatched measurement accuracy, robustness and proven quality.

Technology – Best in class, state of the art and high-precision instruments that keep pace with ever changing and fast evolving optical technology.

Operability – For more than 30 years our R&D and product specialist teams have been listening to the needs of users to continuously provide them with innovative and effective solutions for their measuring challenges.

Standard/High Accuracy models

There are two models available, the ± 0.2 ppm high accuracy model with improved wavelength accuracy (AQ6151B) and the ± 0.7 ppm standard model (AQ6150B).

Standard/Extended/Wide range type

Standard: for telecom device testing from O to L-Band

Extended: for CWDM transceiver testing

Wide range: for pump laser testing

Multi wavelength/Single wavelength type

You can choose between multi wavelength detection capable of simultaneous measurement of multiple wavelengths such as WDM signal or single wavelength detection, which is enough to characterize a transceiver module, LD chip or even the wafer level output.

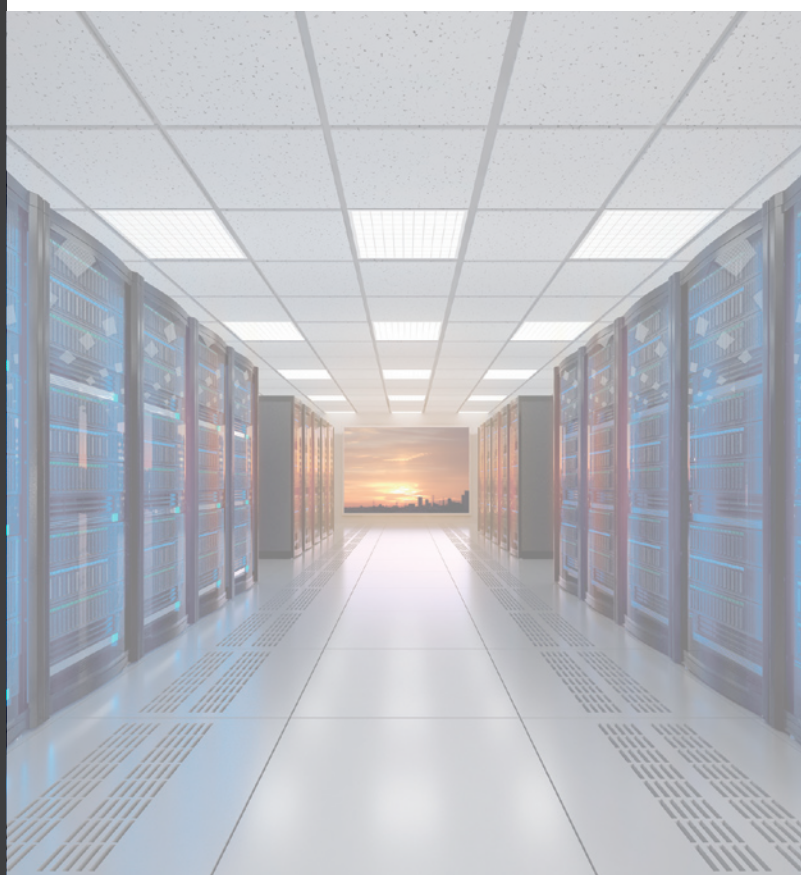

2X Faster measurement speed*

For the production of tunable laser sources and tunable optical transceivers, high speed measurement and processing capability are required. The AQ6150 series can acquire, analyze and transfer a measurement to a PC within 0.2 seconds.

*Compared with our previous models.



Model		Wavelength	Accuracy	Maximum number of wavelengths	Application
High accuracy model AQ6151B	Standard	1270 to 1650 nm	±0.2 ppm	1024 (Multi-wavelength) 1 (Single-wavelength)	Adjustment, characterization, and inspection of laser chips, tunable lasers, WDM transmission systems, etc.
	Extended	1200 to 1700 nm			
	Wide range	900 to 1700 nm			
Standard model AQ6150B	Standard	1270 to 1650 nm	±0.7 ppm	1024 (Multi-wavelength) 1 (Single-wavelength)	Inspection of DFB-LDs, tunable lasers, optical transceivers. WDM transmission systems
	Extended	1200 to 1700 nm			
	Wide range	900 to 1700 nm			



Excellent wavelength measurement performance

High wavelength accuracy of ± 0.2 ppm

There are two models in this series. The High Accuracy AQ6151B model offers an accuracy of ± 0.2 ppm to meet the most demanding precision requirements. The Standard Accuracy AQ6150B offers a ± 0.7 ppm accuracy for applications with less demanding requirements, at a more affordable price.

The real time correction feature utilizes a highly stable reference signal from the built-in wavelength reference light source in order to provide long-term stability for each and every measurement taken.

CW, modulated transceiver and optical filter measurement

The optical output of optical transceivers and optical transmission systems is modulated with a transmission frequency including 10 G and 25 Gbps. The built-In Optical Spectrum Analysis capability utilizing an FFT technique is required to measure the spectrum broadened by the modulated signal.

In addition to the regular CW light mode, the AQ6150 Series has a modulated light mode. The modulated mode analyzes the optical spectrum and discovers the center wavelength of the modulated light. This mode can also be used for the center wavelength measurement of optical filters such as a band pass filter, AWG and WSS.

Simultaneous measurement of up to 1024 wavelengths

AQ6150 series can measure up to 1024 wavelengths in a single input signal with a minimum separation of 5 GHz simultaneously, quickly, and accurately. This means it can meet testing needs in the development and production of WDM transmission system today and in the future as well. The multi-wavelength measurement capability contributes to production efficiency and cost reduction in the production of single-wavelength laser devices as well, by combining multiple laser modules or optical transceivers using an optical coupler and measuring all the signals at once.

Delivering high performance even with low-power input signals

Equipped with an Auto Gain Control (AGC) function, the AQ6150 Series adjusts the gain of the electrical amplifier automatically based on the input signal power. This helps maximize wavelength accuracy and measurement speed even if the input signal power is as low as -40 dBm.



Improve productivity

Increase throughput with high speed measurement

For the adjustment and characterization of tunable laser sources and tunable optical transceivers requiring hundreds of wavelength measurements per device, high-speed measurement and processing capability are crucial for improving the production throughput.

Both models can acquire, analyze and transfer a measurement to a PC in less than 0.2 seconds! This is 2 times faster than our AQ6150 or AQ6151 model, thus vastly improving production throughput. In the Repeat measurement mode, the AQ6150 series can collect 10 measurements per second, making it extremely useful when adjusting a device while monitoring the wavelength in real time.

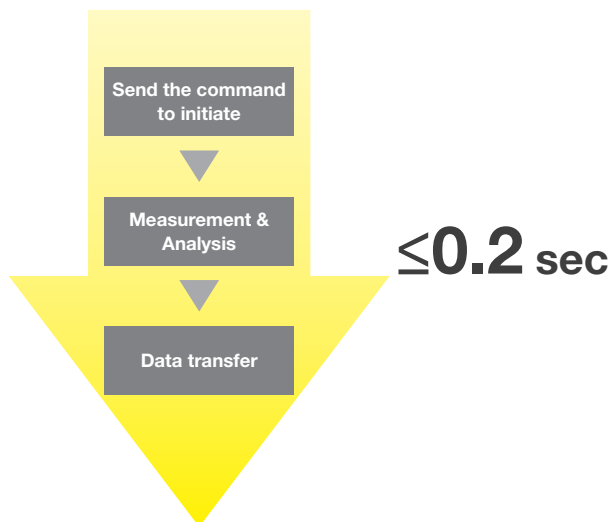
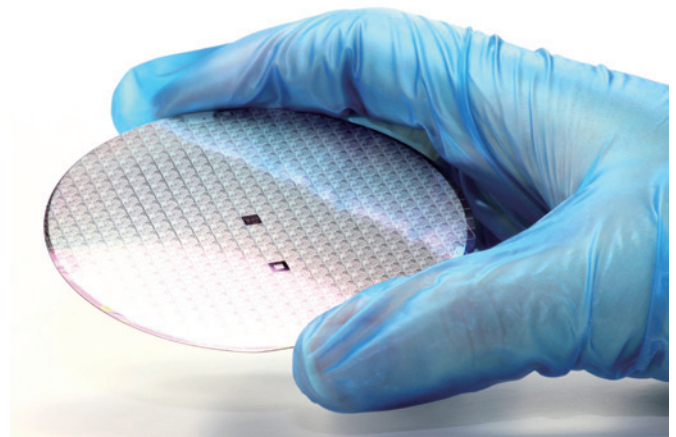

Upgrade the test system with ease

Easily build an automated measurement system using a remote control interface, ETHERNET or GP-IB. The remote command set complies with the commonly accepted SCPI industry standard command set for programmable instruments. Thus, the existing measurement system can be easily upgraded without having to change the measurement program if Yokogawa AQ6140 series or another SCPI compatible optical wavelength meter is already in use.

Reduce lifetime ownership costs

With the conventional wavelength meters, the high failure rate of the wavelength reference light source and its high replacement costs have been a major contribution to the overall costs of ownership during the product life cycle, not to mention the costs generated by the downtime itself. One of our key targets for product design was to address and mitigate as much as possible these issues. We achieved this goal in a multi-dimensional approach as represented graphically in the below scheme.

- Extending the typical lifetime (MTBF) of the light source (Maximize Horizontal scale).
- Reducing the replacement cost (Minimize Vertical scale).

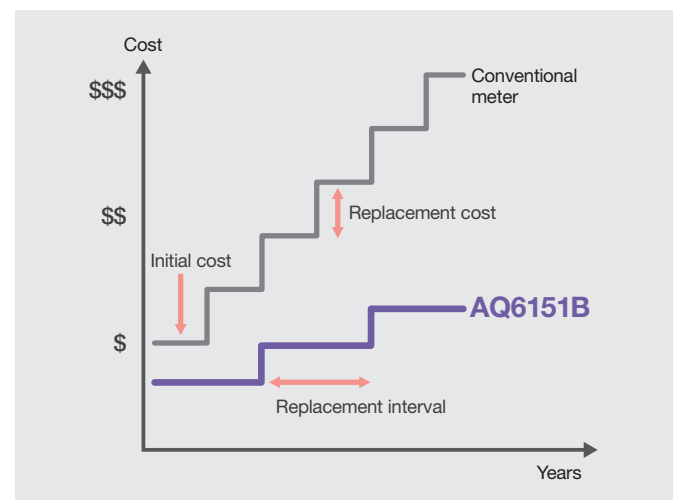

Lifetime cost savings

Choose your preferred view mode

Single wavelength mode

The single wavelength mode displays the wavelength and power of the highest peak or an arbitrary peak using large easy to read numbers. This allows the values to be easily read even if the unit is placed at the top of the test stand.



The horizontal bar graph easily identifies the optical power variation and flatness of the signal.

Multi wavelength mode

The multi wavelength mode displays a list of wavelengths and power of multiple peaks with the wavelength and power of the highest peak or an arbitrary peak on top of the list. There is also a mode to show the list only to maximize the number of channels shown on the screen.



Delta wavelength mode

The delta wavelength mode calculates and displays the difference between a reference peak and the other peaks in terms of wavelength and power. This mode helps determine the peak spacing.

Grid mode

Displays the deviation between a set grid wavelength and a measured wavelength which is within a set search area centering the set grid wavelength.

No.	GRID (nm)	PEAK (nm)	DEV(nm)	PL(dBm)
90	1549.3150	1549.3146	-0.0004	-8.76
89	1550.1161	1550.1008	-0.0153	-7.89
88	1550.9180	1550.9428	0.0248	-8.67
87	1551.7208			
86	1552.5244	1552.5241	-0.0003	-9.30
85	1553.3288	1553.3272	-0.0016	-9.41
84	1554.1340	1554.1345	0.0004	-9.20
83	1554.9401	1554.9396	-0.0005	-7.60
82	1555.7471			

Various measurement units

Choose from any of the following measurement units.

- Wavelength: Wavelength (nm), Frequency (THz), or Wave Number (cm⁻¹)
- Power: dBm, mW, or μW

Optical spectrum view

The AQ6150 series can display an optical spectrum waveform obtained from a Fast Fourier Transform (FFT) algorithm. It allows for determining test conditions and for troubleshooting an error in the measurement while confirming the actual spectrum.

When a peak is selected on the list, the peak automatically shifts to the center of the optical spectrum view, making viewing easy and convenient.

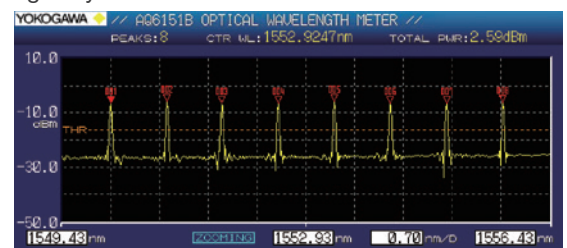

No programming required with built-in analysis functions

The AQ6150 series is equipped with automatic measurement and analysis functions. These functions save valuable time and resources by creating/validating remote control and analysis programs.

Drift analysis

The drift analysis measures the variation of wavelength and power for each peak over time by repeating the measurement. It obtains maximum value (MAX), minimum value (MIN), and variation (MAX-MIN). This function is useful for long-term stability testing and for evaluating the temperature dependency of lasers.

No.	WL(nm)	PW(dBm)	MAX-MIN(nm)	MAX-MIN(dB)
1	1544.9706	-11.32	0.0009	0.07
2	1546.1009	-11.69	0.0010	0.12
3	1547.2334	-8.65	0.0009	0.13
4	1548.3670	-9.48	0.0010	0.03
5	1549.5023	-3.24	0.0009	0.05
6	1550.6394	-11.35	0.0010	0.09

<DRIFT ANALYSIS>
 REF PEAK No.: 5
 REF WL: 1549.5015nm
 ELAPSED: 00:01:07
 REF POWER: -3.28dBm

Drift analysis result

Fabry-Perot laser analysis

The evaluation parameters of a Fabry-Perot laser can be analyzed and displayed instantly from the measured optical spectrum.

Results include:

Center wavelength, total power, spectral-width (FWHM), mode spacing, etc.

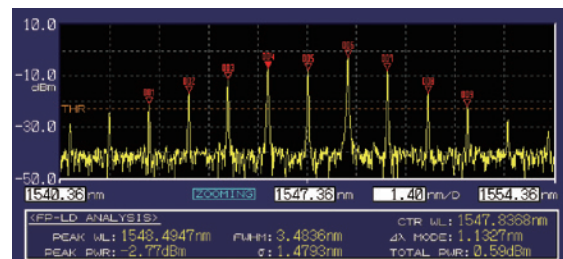

Fabry-Perot laser analysis

Average measurement

The Average measurement obtains an average wavelength and power for each peak by repeating the measurement. This function helps reduce uncertainty of measurement for a modulated signal or unstable signals.

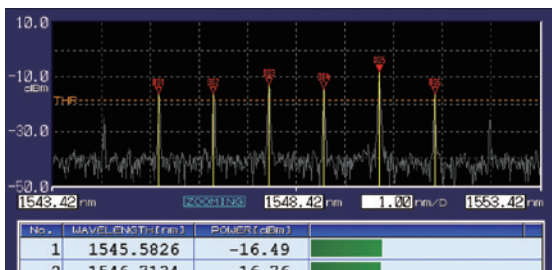

Average measurement screen

Data logging function

Up to 100001 points of measurement data per channel can be stored and displayed in tabular or graph form. It facilitates the long-term stability test and temperature cycle test.



User-friendly interfaces

Proven design and operability

The AQ6150 series' screen design and intuitive operability is inherited from YOKOGAWA's best-selling optical spectrum analyzer. This interface has been proven by a vast population of users on a global scale in areas such as R&D testing and troubleshooting in manufacturing.

USB ports

- Compatible with USB data storage devices, mouse and keyboard.
- File function enables users to save data and screenshots to the internal memory or USB storage to use when creating test reports. Screenshots can also be saved by simply pressing the Print Screen button (PRT SCN) located on the front panel.

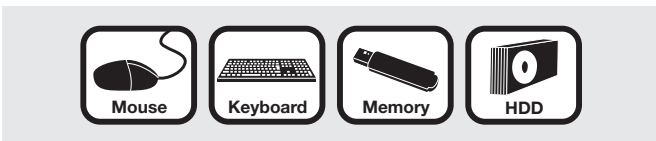

Four ports in total are available on front and rear panels

Easy-to-view bright color LCD

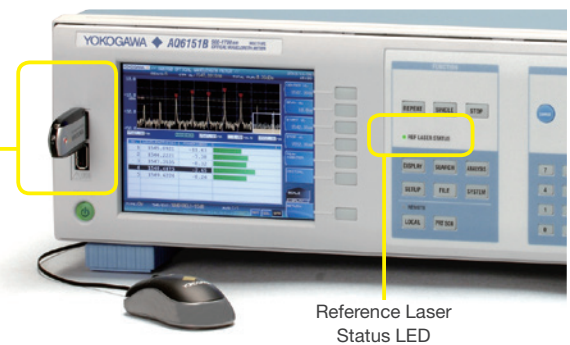

Data access through LAN

The standard LAN port allows convenient access to files stored in the internal memory as well as ability to remotely update the firmware from a PC.

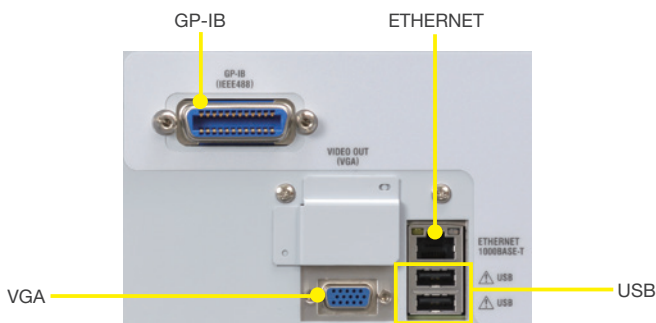

GP-IB, ETHERNET, USB, VGA monitor output on the back panel

Direct operation with mouse

- Using a USB mouse makes it easy and intuitive to change measurement conditions, execute an analysis, and modify the optical spectrum view.
- In the optical spectrum view, the waveform view area can be zoomed and shifted by a simple click and drag. The peak threshold line, threshold for peak detection, can also be moved in the same manner.

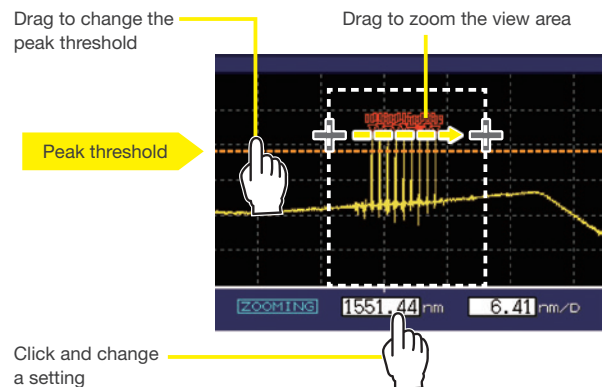

Applications

WDM transmission systems

In order to meet the rigorous demands of current and next generation communication networks, developers are constantly challenged to improve the efficiency and capacity of the transmission system. In response to these challenges, various techniques have been developed, such as minimizing channel spacing, maximizing the number of channels and transmission rate, using sophisticated modulation schemes, etc.

In WDM transmission system testing, high wavelength accuracy is required for testing the system's internal circuit boards such as laser modules and optical transceivers as well as the final output signal of the system, which may involve:

- Simultaneous measurement of multi channel and narrow spacing WDM system
- Precise adjustment and inspection of laser sources
- Measurement of modulated signals

Lasers/optical transceivers

Testing of optical components used in WDM transmission systems such as laser devices, laser modules, and optical transceivers also requires high wavelength accuracy. These applications may include:

- Precise adjustment and inspection of tunable lasers
- Modulated signal measurement of optical transceivers and transponders.
- Measurement of all channels of 40 G and 100 G optical transceivers with WDM technology.

Calibration of test systems

Due to the high accuracy of the AQ6150 series, it can be used for precision wavelength calibration applications including:

- Calibration of optical spectrum analyzers
- Calibration of DFB lasers for optical amplifier test system.
- Calibration of tunable lasers for passive component test systems.

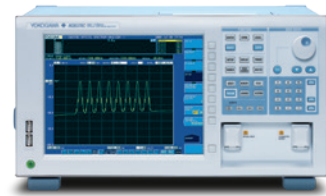

NOTE:

The AQ6370 Series Optical Spectrum Analyzer is recommended for measuring Side Mode Suppression Ratio (SMSR) of lasers and Optical Signal to Noise Ratio (OSNR) of WDM transmission systems.

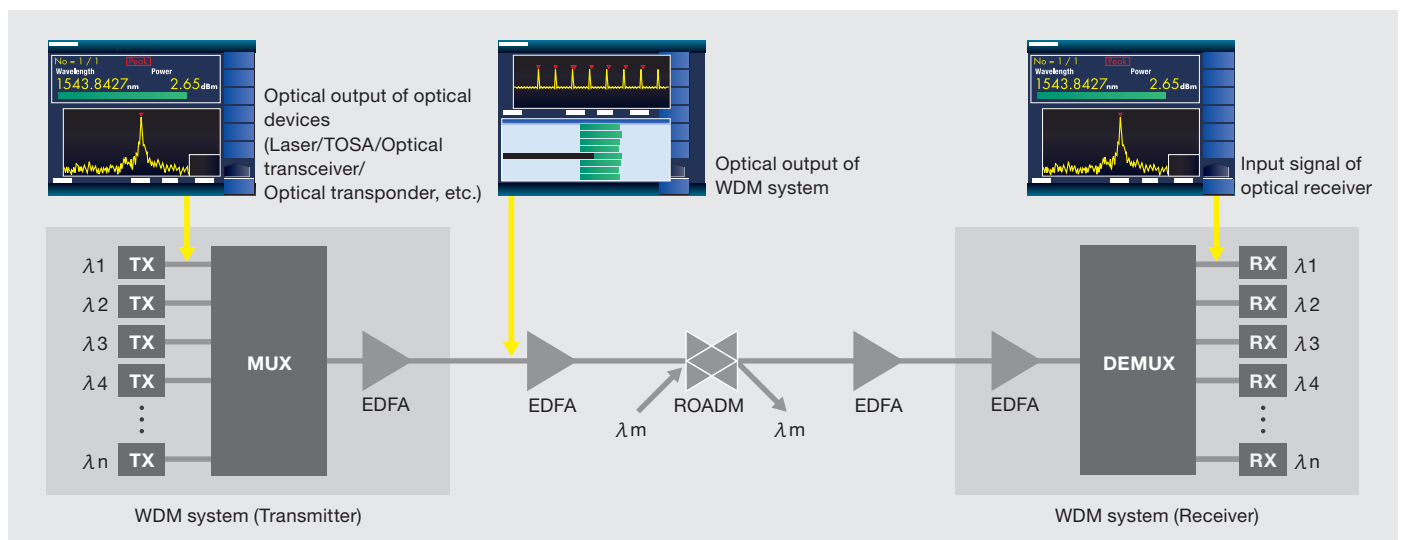

Interfaces

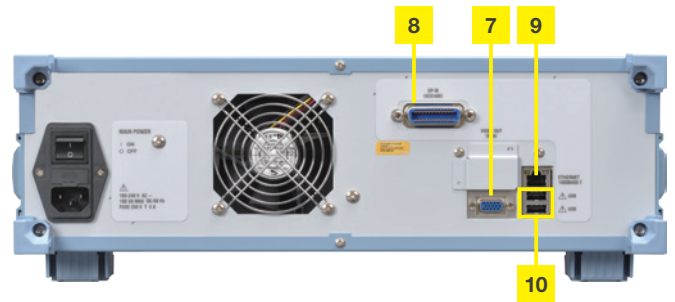

- 1 Display**
Displays measured waveforms, measurement conditions, measured values, etc.
- 2 OPTICAL INPUT**
Connect the optical input signal here.
- 3 Soft key**
Control the functions that are assigned to soft keys, which appear on the right of the LCD display.
- 4 USB port**
Connect a USB storage medium, USB mouse, or USB keyboard.
- 5 FUNCTION**
Set all features including measurement, setup, and display.
- 6 DATA ENTRY**
Enter measurement condition parameters and labels.
- 7 VIDEO OUT**
Video signal (VGA) terminal
Use this terminal to view the instrument screen on an external display.
- 8 GP-IB connector**
Use this connector to control the instrument from a PC.
- 9 ETHERNET port**
Use this port to connect the instrument to a network. (10/100/1000BASE-TX)
- 10 USB port**
Connect a USB storage medium, USB mouse, or USB keyboard.

Principle

Michelson interferometer

Generate interference by changing the optical path length difference between the fixed mirror and the movable mirror. Then detect the interference signal with the optical receiver.

Fast Fourier transform (FFT)

Convert the interference signal (interferogram) into the optical spectrum waveform.

Fast data processing

Analyze the given optical spectrum waveform. Then output the wavelength and power data of the input signal.

Real-time wavelength correction

Correct the measurement error by simultaneously measuring the interference signal of the reference wavelength while measuring the input signal.

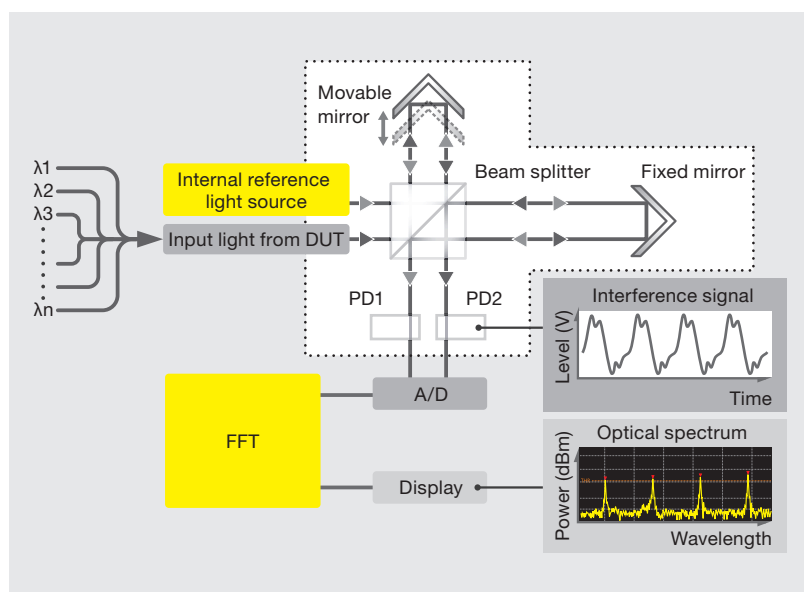

Specifications

AQ6150B/AQ6151B

Items		Specifications					
Model		AQ6150B			AQ6151B		
		Standard (-10)	Extended (-20)	Wide range (-30)	Standard (-10)	Extended (-20)	Wide range (-30)
Wavelength	Wavelength range	1270 to 1650 nm	1200 to 1700 nm	900 to 1700 nm	1270 to 1650 nm	1200 to 1700 nm	900 to 1700 nm
	Wavelength accuracy ¹	±0.7 ppm (±1 pm at 1550 nm, update rate: Normal) ±1.5 ppm (±2.3 pm at 1550 nm, update rate: Fast)		±0.7 ppm (1200 to 1700 nm, ±1 pm at 1550 nm, update rate: Normal), ±1.5 ppm (1200 to 1700 nm, ±2.3 pm at 1550 nm, update rate: Fast), ±1.5 ppm (900 to 1200 nm, ±1.4 pm at 900 nm)	±0.2 ppm (±0.3 pm at 1550 nm, update rate: Normal) ±0.5 ppm (±0.8 pm at 1550 nm, update rate: Fast)		±0.2 ppm (1200 to 1700 nm, ±0.3 pm at 1550 nm, update rate: Normal), ±0.5 ppm (1200 to 1700 nm, ±0.8 pm at 1550 nm, update rate: Fast), ±1.5 ppm (900 to 1200 nm, ±1.4 pm at 900 nm)
	Minimum resolvable separation ^{2,3}	5 GHz (40 pm at 1550 nm, update rate: Normal) 10 GHz (80 pm at 1550 nm, update rate: Fast)					
	Display resolution	0.0001 nm					
Power ⁴	Power accuracy ⁵	±0.5 dB (1550 nm, -10 dBm)					
	Linearity ⁵	±0.3 dB (1550 nm, -30 dBm or higher)					
	Polarization dependency ²	±0.5 dB (1550 nm)					
	Display resolution	0.01 dB					
Maximum number of wavelengths		1024 (1 for Single-wavelength type)					
Minimum input power ^{4,6}		-40 dBm (1270 to 1600 nm), -30 dBm (1600 to 1650 nm)	-40 dBm (1200 to 1600 nm), -30 dBm (1600 to 1700 nm)	-40 dBm (1200 to 1600 nm), -30 dBm (900 to 1200 nm, 1600 to 1700 nm)	-40 dBm (1270 to 1600 nm), -30 dBm (1600 to 1650 nm)	-40 dBm (1200 to 1600 nm), -30 dBm (1600 to 1700 nm)	-40 dBm (1200 to 1600 nm), -30 dBm (900 to 1200 nm, 1600 to 1700 nm)
Maximum input power		+10 dBm (total input power)					
Safe maximum input power		+18 dBm (total input power)					
Applicable optical fiber		SM (ITU-T G.652)					
Return loss ²		35 dB					
Measurement time ⁷		0.2 s or less (update rate: Fast), 0.3 s or less (update rate: Normal)					
Display ⁸		5.7-inch color LCD (640 × 480 dots)					
Data storage		Internal: 256 MB or more, External: USB					
Interfaces		GP-IB, ETHERNET, USB, VGA output					
Remote control		GP-IB, ETHERNET					
Optical connector		FC/PC or SC/PC (AQ9441 Universal adapter)					
Warm-up time		60 minutes or more					
Power requirements		100 to 240 VAC, 50/60 Hz, approx. 100 VA					
Environmental conditions		Performance guarantee temperature: +10 to +30°C, operating temperature: +5 to +35°C, storage temperature: -10 to +50°C, humidity: 20 to 85%RH (no condensation)					
Dimensions and mass		Approx. 426 (W) × 132 (H) × 450 (D) mm (excluding protrusions), approx. 11 kg					
Safety standards		EN61010-1					
EMC	Laser	EN60825-1: 2014, IEC60825-1: 2007, GB7247.1-2012 Class 1					
	Emission	EN61326-1 Class A, EN55011 Class A Group 1, EN61000-3-2, EN61000-3-3					
	Immunity	EN61326-1 Table 2					
RoHS		EN50581					
Recommended calibration period		1 year					
Accessories		Power cord: 1, rubber feet: 1, CD-ROM (user's manuals): 1, Getting started guide: 1					



Complies with 21 CFR 1040.10 and 1040.11 except for deviations pursuant to Laser Notice No.50, dated June 24, 2007
2-9-32 Nakacho, Musashino-shi, Tokyo 180-8750, Japan

*1: Line spectrum, CW, constant polarization during measurement, vacuum wavelength, input power -30 dBm or higher, line separation 10 GHz or more (update rate: Normal) or 20 GHz or more (update rate: Fast) in case of multi-line measurement, excluding the influence of absorption of OH group, confidence level (k=3)

*2: Typical

*3: Not valid for Single-wavelength type. Equal power lines input.

*4: Update rate: Normal

*5: Line spectrum, CW, excluding polarization effects

*6: Single line input

*7: Single measurement, number of detected wavelengths 128 or less

*8: Liquid crystal display may include a few defective pixels (within 0.002% with respect to the total number of pixels including RGB). There may be a few pixels on the liquid crystal display that do not emit all the time or remains ON all the time. These are not malfunctions.

Functions

Items	Specifications
Measurement	Single, repeat, average, drift, data logging
Measurement condition setup	Average count, air/vacuum wavelength, device type (CW/modulated), measurement range, update rate
Display	Single-wavelength, multi-wavelength*, delta*, grid, spectrum (with zooming)*, wavelength axis units [wavelength (nm) /frequency (THz) /wave number (cm ⁻¹)], optical power units (dBm/mW/μW), center wavelength*, total power*, marker (up to 1024 points)*, label, power bar, warning messages, error messages, system information
Data analysis	Peak search*, FP-LD analysis*, drift analysis, WDM (OSNR) analysis
File	Saving/loading measured results (CSV), saving/loading setup parameters (binary), saving screen images (BMP), saving/loading logging data (BIN, CSV)
Remote control	Interface selection (GP-IB/Ethernet), TCP/IP configuration, remote monitor
Others	Internal reference light source status LED, optical power offset, parameter initialization, firmware updating

*Multi-wavelength type only

Ordering information

Model and suffix code

Model	Suffix	Descriptions
AQ6150B		AQ6150B Optical Wavelength Meter
AQ6151B		AQ6151B Optical Wavelength Meter
Spec code	-10	Standard type (1270 to 1650 nm)
	-20	Extended type (1200 to 1700 nm)
	-30	Wide range type (900 to 1700 nm)
Wavelength detection	-SW	Single-wavelength type
	-MW	Multi-wavelength type
Optical input connector	-FCC	FC/PC (AQ9441 Universal Adapter)
	-SCC	SC/PC (AQ9441 Universal Adapter)
Power cord	-D	UL/CSA standard and PSE compliant, 125 V
	-F	VDE/Korean standard, 250 V
	-R	Australian standard, 250 V
	-Q	British standard, 250 V
	-H	Chinese standard, 250 V
	-N	Brazilian standard, 250 V
	-T	Taiwanese standard, 125 V
	-B	Indian standard, 250 V

Accessories (optional)

Model	Suffix	Descriptions
813917321		AQ9441 Universal Adapter
	Connector type	-FCC FC type
		-SCC SC type
751535	-E3	Rack mount kit (inch type)

YOKOGAWA

YOKOGAWA TEST & MEASUREMENT CORPORATION

Global Sales Dept. /Phone: +81-422-52-6237 E-mail: tm@cs.jp.yokogawa.com
Facsimile: +81-422-52-6462

YOKOGAWA CORPORATION OF AMERICA

YOKOGAWA EUROPE B.V.

YOKOGAWA SHANGHAI TRADING CO., LTD.

YOKOGAWA ELECTRIC KOREA CO., LTD.

YOKOGAWA ENGINEERING ASIA PTE. LTD.

YOKOGAWA INDIA LTD.

YOKOGAWA ELECTRIC CIS LTD.

YOKOGAWA AMERICA DO SUL LTDA.

YOKOGAWA MIDDLE EAST & AFRICA B.S.C(c)

Phone: +31-88-4641000
Phone: +86-21-6239-6363
Phone: +82-2-2628-3810
Phone: +65-6241-9933
Phone: +91-80-4158-6396
Phone: +7-495-737-78-68
Phone: +55-11-3513-1300
Phone: +973-17-358100

E-mail: tmi@us.yokogawa.com
E-mail: tmi@nl.yokogawa.com
E-mail: tech@ysh.com.cn
E-mail: TMI@kr.yokogawa.com
E-mail: TMI@sg.yokogawa.com
E-mail: tmi@in.yokogawa.com
E-mail: info@ru.yokogawa.com
E-mail: tm@br.yokogawa.com
E-mail: help.ymatmi@bh.yokogawa.com

Facsimile: +86-21-6880-4987
Facsimile: +82-2-2628-3899
Facsimile: +65-6241-9919
Facsimile: +91-80-2852-1442
Facsimile: +7-495-737-78-69
Facsimile: +973-17-336100

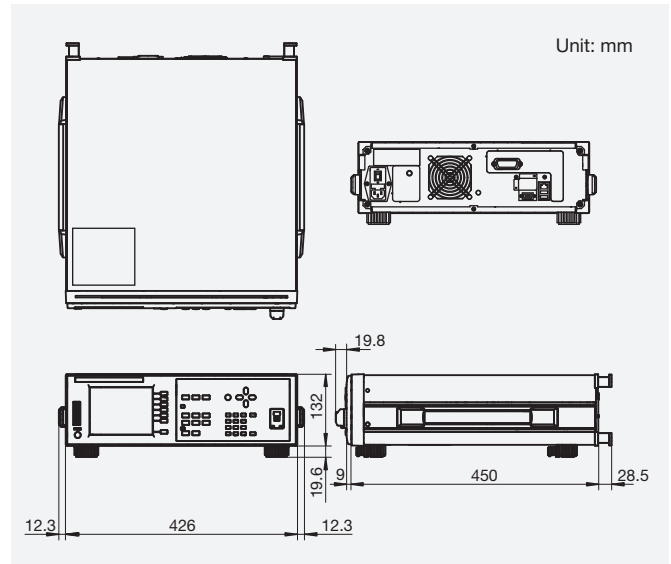

Yokogawa's approach to preserving the global environment

- Yokogawa's electrical products are developed and produced in facilities that have received ISO14001 approval.
- In order to protect the global environment, Yokogawa's electrical products are designed in accordance with Yokogawa's Environmentally Friendly Product Design Guidelines and Product Design Assessment Criteria.

This is a Class A instrument based on Emission standards EN61326-1 and EN55011, and is designed for an industrial environment.

Operation of this equipment in a residential area may cause radio interference, in which case users will be responsible for any interference which they cause.

- Any company's names and product names mentioned in this document are trade names, trademarks or registered trademarks of their respective companies.

NOTICE

- Before operating the product, read the user's manual thoroughly for proper and safe operation.

<https://tmi.yokogawa.com/>

YMI-KS-MI-SE06

The contents in this catalog is as of November 2018. Subject to change without notice.

Copyright © 2012, Yokogawa Test & Measurement Corporation

[Ed: 04/b]

Printed in Japan, 811(KP)

Revisions

Bulletin AQ6150SR-01EN 4th Edition

There are some revisions in this brochure. Please be aware of the changes below.

1. Specifications (page 11)

- Dimensions and mass On the brochure: Approx. 426 (W) × 132 (H) × 450 (D) mm (excluding protrusions)
 Revision: Approx. 426 (W) × 132 (H) × 459 (D) mm (excluding protrusions)

2. Ordering information (page 12)

- Model and suffix code

On the brochure:

Models	Suffix	Descriptions
AQ6150B		AQ6150B Optical Wavelength Meter
AQ6151B		AQ6151B Optical Wavelength Meter
Optical input connector	-FCC	FC/PC (AQ9441 Universal Adapter)
	-SCC	SC/PC (AQ9441 Universal Adapter)
Power cord	-D	UL/CSA standard and PSE compliant, 125 V
	-F	VDE/Korean standard, 250 V
	-R	Australian standard, 250 V
	-Q	BS/Singaporean standard, 250 V
	-H	Chinese standard, 250 V
	-N	Brazilian standard, 250 V
	-T	Taiwanese standard, 125 V
	-B	Indian standard, 250 V

Revision:

Models	Suffix	Descriptions
AQ6150B		AQ6150B Optical Wavelength Meter
AQ6151B		AQ6151B Optical Wavelength Meter
Optical input connector	-FCC	FC/PC (AQ9441 Connector Adapter)
	-SCC	SC/PC (AQ9441 Connector Adapter)
Power cord	-D	UL/CSA standard and PSE compliant, 125 V
	-F	VDE/Korean standard, 250 V
	-R	Australian standard, 250 V
	-Q	BS/Singaporean standard, 250 V
	-H	Chinese standard, 250 V
	-N	Brazilian standard, 250 V
	-T	Taiwanese standard, 125 V
	-B	Indian standard, 250 V
-U	IEC Plug Type B, 250 V	



- Accessories (optional)

On the brochure:

Models	Suffix	Descriptions
813917321		AQ9441 Universal Adapter
Connector type	-FCC	FC type
	-SCC	SC type

Revision:

Models	Suffix	Descriptions
AQ9441		AQ9441 Connector Adapter
Optical input connector	-FC	FC type
	-SC	SC type

